

# **KLONDIKE DERBY**

## **2012 Participation Guide**



**Test Your Winter Snow Skills!**

**FRIDAY-SUNDAY, FEBRUARY 17-19, 2012**  
**Pinecrest, California**

Sponsored by  
**Toloma Lodge**  
**Greater Yosemite Council**  
**Boy Scouts of America**

## Welcome to Order of the Arrow Klondike Derby!

The Klondike Derby will be held at Meadow View Campground area in the Pinecrest Recreation Area (See Map below). This is the premier winter camping event for the Greater Yosemite Council Scouts. Please note the instructions included in this publication carefully, and make sure that your Scouts are well prepared, and well equipped to participate in the Klondike, and most of all to have a GREAT experience. If you have not already planned to do so, it is a good idea to have a Klondike “Shake down” campout prior to the Klondike Derby. This is useful for many reasons, but most of all to let your Scouts get a feel for what to expect, and what equipment and clothing they might need to improve on, and to check out their Scout craft skills, sledge-running abilities, and a variety of other items.

If you have any question or concerns, please feel free to contact any member of the Order of the Arrow for assistance prior to or at the Klondike Derby. The Order of the Arrow Lodge is anxious to make this the best experience for the Council Scouts and Scouters. We welcome your help, and your advice. If your unit has older Scouts and/or Scouters who would like to assist or be part of the Staff, or to assist with operating the "cities," please have them contact us right away.

Yours in Scouting,

Toloma Lodge

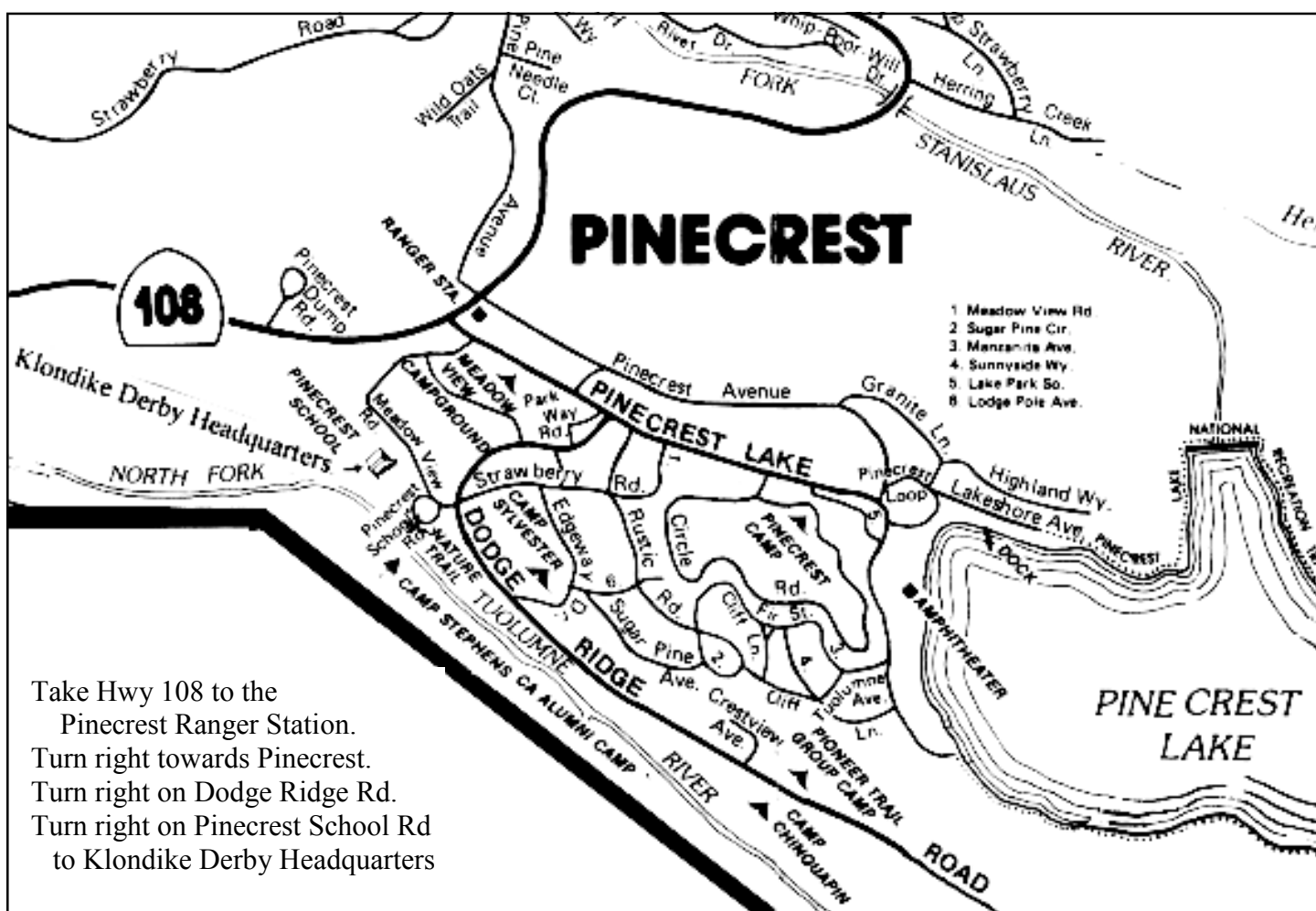

# **\*\* KLONDIKE DERBY \*\***

**Friday-Sunday, February 17-19, 2012**

**Klondike Headquarters:** Pinecrest Community Hall, 2 Pinecrest School Rd, Pinecrest, California.

**Cost:** The fee is \$15.00 per registered Scout or Scouter. Registration is transferable within a unit.

Your unit may choose either of the following sessions:

(1) Fri-Sat, Feb 17-18 or (2) Sat-Sun, Feb 18-19

**Note:** All Scouts and Scouters must be "layered" for cold weather. This includes proper footwear (no tennis shoes). Be Prepared for a clothing inspection by the "Royal Mounties." See Health and Safety Section!

## **KLONDIKE DERBY SCHEDULE**

**Check-In** - Units must check in first at Klondike Derby Headquarters to confirm pre-registration information and receive your campsite assignments. The Check-In time is 4:00 PM to 8:00 PM on Friday and 4:00 PM to 6:00 PM on Saturday. PLEASE DO NOT ARRIVE BEFORE CHECK-IN TIME. Read carefully the "Parking at Meadow View Campground" page in this guide.

**8:00 PM - OA Campfire** (except Friday Night)

**8:30 PM- Klondike Meeting.** Meeting of the SPL and Scoutmaster only.

**8:30 AM - Opening Flag.** Ceremony (parking lot)

**9:00 AM to 2:00 PM - Activities.** This is the Gold Rush Klondike Derby. The activity locations are the Alaskan cities on the way to the Klondike. At each city the "Mayor" will award "OA Gold Certificates" for the patrol's performance. The Patrols will be able to use these "OA Gold Certificates" at the Trading Post.

Klondike Sledges should be built "as closely as possible" to the specifications on the enclosed plans and will be inspected before the events starts.

The youth and leaders of the Toloma Lodge of the Order of the Arrow will run the events.

**Check Out by 3:00 PM** - Campsites must be inspected and pass the inspection by 2:00 PM of the Unit's check out day.

**3:00 P.M. Awards Ceremony.** Patches and ribbons will be given out at a short meeting.

**Session 2** - Please do not arrive at the Klondike Derby site before 4:00 PM Each Unit may plan activities in the Pinecrest area prior to or after participating in the Klondike Derby such as: Sleds, Cross Country Skis, and safe items such as Inner Tubes or Saucers. Any unit wishing to ski at Dodge Ridge should make their arrangements.

**NOTE:** The Trading Post/Concession Stand will be located at the Headquarters Site. You may purchase candy and soft drinks at the Concession Stand.

The "OA Gold Certificates" may be used ONLY at the **Concession Stand**. Each Patrol Leader will turn in all "OA Gold Certificates" to purchase one Candy or Soda for each member of the Patrol.

# **\*\* KLONDIKE DERBY \*\***

## **Overview**

The Klondike Derby is a three-day Winter Camporee that brings together Scouts and Scouters from the entire Council. The Klondike Derby is an all-day sled race between “Cities” with “Gold Rush” flavor sporting names such as Fort Yukon, Fairbanks, Skagway, etc. Each city has a competitive specialty using the Scout craft skills such as cooking, pioneering, first aid, teamwork, nature, and others. By combining the winter camping experience with the Scout craft competitions, the Klondike provides an opportunity for Scouts to experience new challenges while having a lot of fun. All units are encouraged to participate in this great adventure.

## **Cost and Registration Procedure**

Registration fees are \$15.00 per Scout or Scouter. All attendees should be pre-registered for planning purposes. Registration is transferable within a unit. Please pay registration fees at the Modesto Service Center. If a pre-registered Scout or Scouter is unable to attend due to an emergency, a \$10.00 refund may be made to the Unit’s account.

The fees for this event include a Meadow View Campground rental fee, and the operational costs of awards, patches, insurance, equipment rentals and supplies. We have made every effort to keep the costs down, but this is the best that we can do. Your understanding is appreciated.

## **Meadow View Campground, Pinecrest Recreational Area**

The Klondike Derby has been held at this location since 1997. Previously it was held at various locations. Our first experience at this location was overwhelming, due to the number of participants. It is nice to know that we have created a very successful event. However, the rules in this guide have been made to conform to the requirements that have been placed on this event by the Pinecrest Forest Service. It is very important that Scouts and Scouters follow all the rules and regulations. We must be good Scouting “citizens” to be welcomed back for future Klondike Derby’s.

## **Check-In and Campsite Assignment**

Upon arrival only the Scoutmaster and the Senior Patrol Leader must Check-In at Klondike Derby Headquarters (Pinecrest Community Hall). The Check-In times are 4:00 PM to 8:00 PM on Friday and 4:00 PM to 6: PM on Saturday. Please be prepared as follows:

1. Check-in at the Klondike Derby Headquarters to confirm pre-registration information or provide any last minute changes.
2. Confirm that you have your Tour Permit and that you have medical forms for all participants.
3. Receive your Klondike Derby competition packets for each Patrol. (At the evening meeting).
4. Receive your campsite location assignment.
5. Pick up your Headquarters parking permit.

## **Parking at Meadow View Campground**

The parking at the Pinecrest Community Hall (Klondike Headquarters) is VERY LIMITED. Please respect the residents living next to Community Hall and do not block their driveways. Each Unit will be issued one parking permit for use in the campground area. Place your permit on the driver's side dashboard so it can be easily seen. No parking is permitted on any road in Pinecrest. Vehicles parking on roadways and/or obstructing snowplows will be cited. Parking is allowed only in parking lots. Extra vehicle parking is located in the county parking lot across from the Lake. Each Unit must arrange for their own shuttle service between the campground area and the parking lots. Your cooperation in not parking in restricted areas is extremely important to the safety and success of the Klondike. Please cooperate with the Law Enforcement and Safety Officials coordinating parking to make this work for everyone.

## **Unloading & Loading Equipment at Meadow View Campground**

It is requested that unloading and loading of equipment be made as expeditiously as possible. Keep extra vehicles in the area to a minimum and adhere to the parking requirements listed above.

## **Rules for Winter Camping in the Pinecrest Recreation Area**

1. Be prepared for just about anything while winter/snow camping.
2. This Winter Camporee/Klondike Derby may be difficult for young new Scouts who have not been camping before with your unit. Please be sure to screen and properly prepare those Scouts attending to make sure that everyone will have an enjoyable time.
3. Be sure to file a Tour Permit with your Council Service Center. Be sure that all your Scouts are registered and covered by accident insurance. Winter camping is a beautiful experience when Nature is properly respected, which means it can be dangerous for the unprepared.
4. Camp only in designated campsites.
5. You will need to provide your own water containers, which can be filled at the Headquarters building (Pinecrest Community Hall).
6. Wood fires must be in a campground fire ring, even if you must dig down through the snow to get to it. Fires are prohibited on camp roads or paved surfaces.
7. No straw or the like may be used for ground cover. You may use ground clothes, plastic and cardboard, which must be removed afterward.
8. There is no winter garbage or trash pick up. All trash and garbage must be placed in bags and removed when you leave. Police your campsite carefully. Leave it in better shape than you found it.
9. Portable Toilets - Use Them! Do not "Find a Tree" when you need to "go." It is required that all participants use port-a-potties. Please encourage all units to use these facilities. Continued use of the area is dependent on cooperation with the U.S. Forest Service. Remember; ground latrines or "cat holes" are forbidden.

## **Severe Weather**

The policy for modifying or canceling the Klondike Derby due to extreme winter weather conditions is as follows:

- 1). Winter storm or Blizzard warning in the Pinecrest area;
- 2). Wind chill below -32° F;
- 3). Visibility less than 100 feet;
- 4). Any other non-weather related conditions which the Council, U.S. Forest Service, or the Klondike Derby Staff deem to be unsafe.

Call the Greater Yosemite Council Office for the latest information at (209) 545-6320.

## **Health and Safety**

Scouts must be in proper clothing to participate in the events. Dress to stay warm and comfortable. Don't wear anything made of cotton! It holds moisture, and makes you cold! Winter clothing is most important! Tennis shoes are not appropriate.

During past Klondike Derbies, a number of Scouts have been observed with inadequate or improper clothing for weather conditions that could have resulted in cases of Frostbite and Hypothermia. Be sure to review symptoms of Hypothermia and Frostbite and know how to recognize and treat them.

Be prepared for Sun exposure even in winter. Use sunscreen and sunglasses.

No Snowball Fights. Don't ruin a Scout's experience at the Klondike by hurting him with a snowball.

We recommend extreme caution if traveling at night in snow country. You may arrive early in the Pinecrest area on your check-in day, but please do not arrive at the Klondike Derby site until the official check-in time.

Special Activities: Because of the variety of storms that hit the Sierras in the winter, there should be an abundance of snow.

Be sure to carry chains and travel at a safe speed!

## **Injury or Illness**

Send a runner to the nearest city or Klondike Staff member. Don't move injured patients. Keep them warm and comfortable. Note and report the following:

Exact Location.

What happened? Are they conscious and breathing? Obtain description of injury. How many injured?

Patient's name, age, sex and Unit if known.

What first aid has been given?

Who is with the patient?

Who is caring for the patient?

Time of accident.

## **Forbidden Items (The “No-No” List)**

Listed here are forbidden items, equipment and activities. Remember that violations of some of these guidelines could result in injury to Scouts, or violation of area regulations or BSA rules. If the violation is serious, you could be asked to leave the Klondike. Follow the Scout Oath and Law!

No Ground Latrines. Use the Porta-a-Potties.

All ground fires must be in fire rings.

No cutting of standing trees or limbs, dead or alive. Bring your own wood supply.

No Axes allowed.

No Scouts using liquid fuel equipment. BSA policy states: Adults must light all stoves and lanterns.

No stoves or lanterns on trails allowed.

No open flames in tents.

No smoking is allowed at public events or in any public area. Set a good example.

No Alcoholic beverages or illegal substances allowed. This is not the time nor place.

No snowmobiles except as provided by the Klondike Staff.

Do not wear skis in Klondike Derby area.

No tennis shoes or cotton clothing allowed.

No pooches; leave Fido at home.

No radios or tape players allowed.

No Grouches, Please! (We are here to have fun!)

## **Camp Cleanup and Service Project**

Be sure you leave your campsite cleaner than you found it. Obviously you may not get everything until the snow is gone. In order to provide for this eventuality, a service project day will be scheduled in the spring.

## **Checkout and Receipt of Patches**

Campsites must be inspected and pass the inspection by 2:00 P.M. of the Unit's checkout day to receive your Klondike Derby patches.

## **WEBELOS Participation**

A Scout Unit may sponsor a WEBELOS Den. The WEBELOS Den and adults must be pre-registered by a host Scout Troop. The Klondike Derby can be an important element in continuing the interests of WEBELOS and their parents/guardians in the Scouting Program. Often this is the first major outdoor event experienced by WEBELOS with a Troop that he is considering joining, so the importance of his having a good experience cannot be over estimated. Make sure to have an adult or Senior Scout meet the WEBELOS Den at the Klondike Headquarters upon arrival in the morning. Because parking space is limited at the campground, please car pool as much as possible. Remember that WEBELOS are not allowed to camp overnight with a Troop, unless special arrangements are made so that the WEBELOS has a parent/guardian camping with him. Such arrangements must be made in advance with the host Troop.

## **\*\* KLONDIKE DERBY EVENTS \*\***

**HEADQUARTERS** - Check in with the "Royal Canadian Mounted Police" with your Patrol Roster. All Patrol members must be in proper clothing to proceed to the other events!

**SKAGWAY** - Your Patrol has found a snowmobile rider in a snowdrift. He has a severe cut and bleeding on his leg, has a compound fractured arm, is in shock and has hypothermia. Give him First Aid and transport him on an improvised stretcher to the Juneau Hospital 100 yards away. Only poles will be provided for the stretcher.

**FAIRBANKS** - You will be given a set of compass headings and a "measured pace" distance to bring you to a miner's "Pot of Gold." Bring a compass.

**POLAR COVE** - A will be given a special "Snow Snake" with instructions to enable your Patrol to propel the snake down a special snow alley for the maximum distance.

**KODIAK** - Materials will be given to your Patrol in order to build a big slingshot for throwing snowballs at an inner-tube or target. This is a timed event and will be scored on accuracy and distance.

**ATTU** - This is the Hot Chocolate Chug-A-Lug. You are to build a fire, heat your water and mix cocoa for a Chug-A-Lug contest. Patrols are to bring their own wood, pot and water. Two matches and the cocoa mix will be furnished. No combustible fuels may be used.

**SITKA** - Your Patrol is challenged to a Tug-of-War. Be prepared for a tough pull!

**FORT YUKON** - The sledge and one Scout is separated from the rest of the Patrol by an expanse of 40 feet of (imaginary) thin ice. The Patrol will need to join enough pieces of 6-foot sections of rope so that it can be cast and reach the sledge. The stranded Scout will tie the rope to the sledge and be pulled to safety. Your Patrol will need to bring enough 6-foot pieces of rope.

**SEWARD** - This is the great Klondike Race and you are to be prepared for any catastrophe. You will travel over an obstacle course laid out by the Judges. Any time you come in contact with another Patrol and their sledge you must be prepared to do battle with a suitable supply of snowballs. The object is to move over the course as fast as possible in order to win the race.

**ANCHORAGE** - This event is called Snowball Football. Your Patrol will take a football and you will be matched up with another Patrol in a football game. Rules will be furnished at the site.

**NOME** - Your Patrol will have the opportunity to try Bowling Pins target shoot with snowballs. A course will be set up on a hard snow surface with bowling pins and a bowling ball.

**HEADQUARTERS-A** - This is a special event involving the construction of a snow cave or Igloo. Take the drawings furnished and scoop out a snow cave along the bank of snow piled along the parking area. For those who sleep overnight in the snow cave, a special certificate will be awarded called the "Snowshoe Thompson Award."

**HEADQUARTERS-B** - This is a special event involving the use of snowshoes or skis, either Alpine or Nordic. Scouts will be given a trail to follow for a specific distance. Scouts may use their own equipment or borrow snowshoes or skis to accomplish the assignment. For those who complete it, a special certificate will be awarded called the "Snowshoe Thompson Hikers Award."

**Please note that each patrol will need to carry the equipment needed for each event.  
It can be carried on the Patrol's sledge.**

# KLONDIKE SLEDGE

While your own design will be accepted, this diagram shows an authentic sledge. You may paint them bright colors but varnish or wax the bottom of the runners. Accessories may be added, canvas snow guard for front and sides. Use bolts or screws instead of nails - drill first to avoid splitting. Make towing bridle of rope, about 20 feet.

## Bill of Material

Pt.	Qty.	Description
1	2	-4"x1/2"x6'6" - runner
2	6	-1"x1"x18" - cross support
3	4	-1/2"x4"x5' - floor cover
4	8	-1"x2"x6" - upright support
5	2	-1"x2"x40" - rear upright
6	2	-1"x2"x30 1/2" - 2nd rear upright
7	2	-1"x2"x21 1/4" - 2nd front upright
8	2	-1"x2"x12" - front support
9	2	-1/2"x2"x6'0" - hand rail
10	1	-1/2"x2"x30" - front curved guard
11	1	-2"x2"x18" - rear hand rail
12	1	-1/4"x10"x18" - Pocket holder
13	2	-1"x2"x to suit bracing

Envelope type pocket tack or staple, so Assay Report (6"x8") can be slipped in.  
OR  
CLIPBOARD

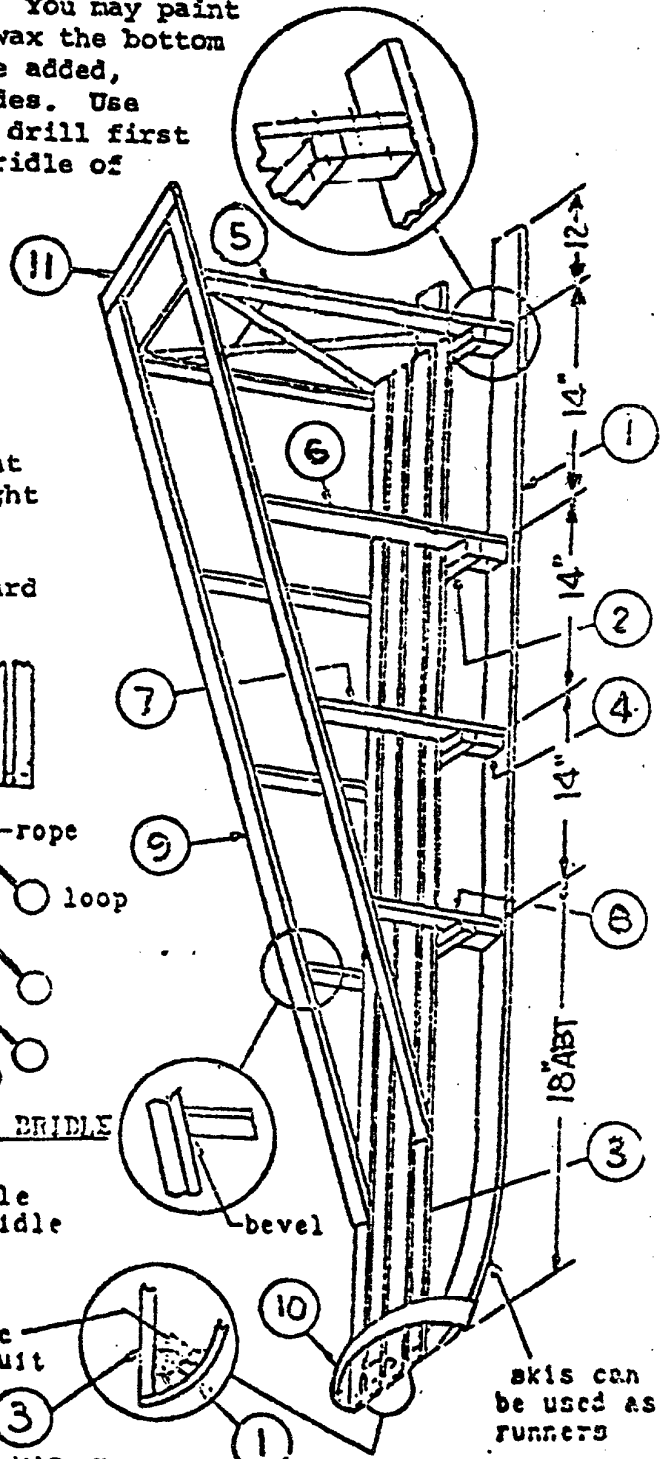
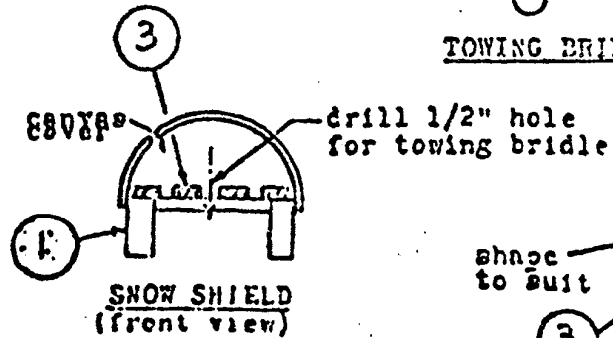
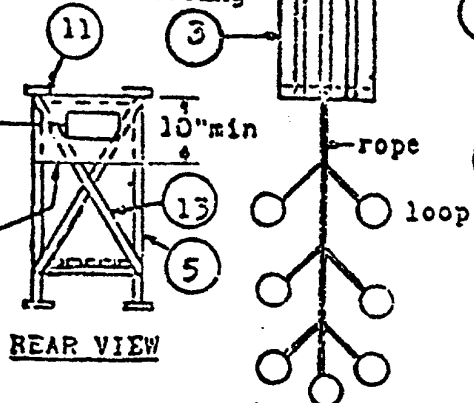

NOTE: SLEDGE MUST BE MADE OF WOOD WITH THE EXCEPTION OF SKIS AS RUNNERS.  
SLEDGE MUST BE CONSTRUCTED BY THE BOYS WITH ADULT SUPERVISION

## How to Make a Snow Snake!

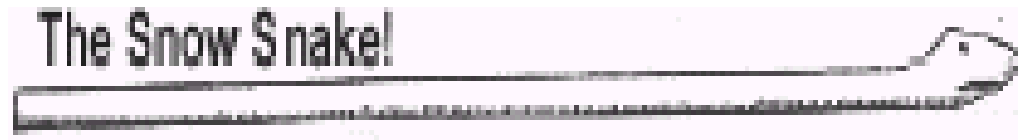

What follows is a brief description of how to make a Klondike Snow Snake which will be used at used at **Polar Cove**. Native Americans traditionally used a snow snake for competitions held among the various Iroquois tribes. The object of the snow snake game was to see who could throw the “snake” the longest distance down a grooved snow and ice track. The snake could be thrown at speeds of up to one hundred and fifty miles an hour.

The natives would form their long grooved track by dragging a straight log through the snow. Once the snow hardened, they would have a long ice track, and these tracks were known to be more than a mile in length!

The snake itself was usually made from a 5 foot long hickory or ash stave. Below is a drawing of the snake.

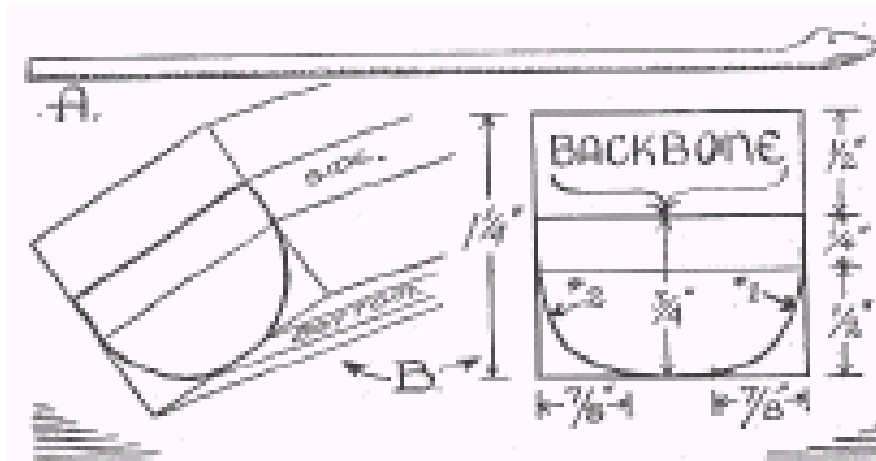

When cutting out your snake, be sure and wear all your safety gear, especially safety glasses!

The snake should be sanded smooth, especially on the bottom of the wood. The natives usually decorated their snake. You can use an upholstery tack to represent the eyes of the snake. The snake once made can then be thrown in either of the following ways: The **underhand method**.



Or the **overhand method**.



The above descriptions are courtesy of Jack Hyland taken from a book called *Indian Games and Crafts*. Thanks Jack!